

Probing systems with infrared transmission

Measuring on machine tools





0.1mm max.
1.0mm max. www.
mh-inprocess.it

HEXAGON

Flexible measuring solutions for machine tools

Hexagon probing systems provide a flexible range of measurement options for machine tools, along with the reliability and precision that ensure consistently high quality and optimised lead times.

Hexagon's modular IRP25.50 touch probe system is suitable for a wide range of applications, making it the perfect foundation for machine tool measurement. Designed for ease of use, versatility and cost-effectiveness, the IRP25.50 system offers a choice of probe extensions and cross-probes, as well as a temperature sensor.

Hexagon probes excel within challenging machine tool environments, whether they are operating under extreme accelerations, high positioning speeds, constant vibrations, hard tool changes, increased temperatures or with coolant. Under all these conditions, Hexagon precision mechanics are able to remain wear-free and highly precise over many years.

The m&h IRP25.50 system

- Reliable HDR+ infrared transmission
- ITE technology – pre-positioning with high-speed
- Safe, reliable activation methods
- Up to 1000 hours of continuous use before battery change
- Robust, flexible and future-proof

Benefits:

- A single, modular base, supporting different measuring units
- Cost-effective
- Reduced storage costs
- Evolves in line with future requirements

m&h IRP25.50: Beyond flexibility

Hexagon offers two functional principles, as well as a temperature measuring unit, which guarantees uncompromising precision under rough conditions in the machine tool.



m&h IRP25.50-PP

The PP version is equipped with the PP41.00 measuring unit, which contains a tripod system. It is suited to the majority of measuring tasks, making it the ideal probe for universal use. It can operate with cross probes and allows for the trigger force to be set.



m&h IRP25.50-MY

The MY version is equipped with the MY21.00 measuring unit with its patented hemisphere system. Its homogeneous probing behaviour makes it especially advisable for machines without rotation spindles.



m&h IRP25.50-TP

The TP version is equipped with the TP44.10 temperature measuring unit with patented temperature measuring technology. The right solution for consistent manufacturing quality or cost-intensive workpieces.

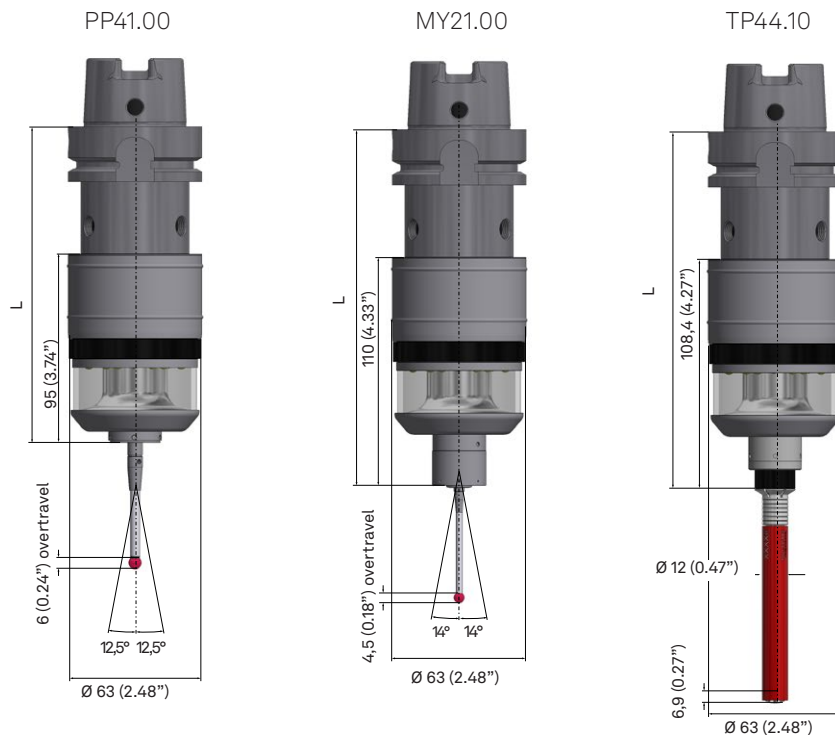

Description	Measuring unit PP41.00	Measuring unit MY21.00	Measuring unit HPP41.10
Repeatability at probing from one direction	Max. 1 µm (2 Sigma) with 50 mm stylus and 254 mm/min probing feedrate	Max. 1 µm (2 Sigma) with 50 mm stylus and 254 mm/min probing feedrate	Measuring accuracy * ±0,1° C
Recommended probing feedrates	Max. 2000 mm/min	Max. 2000 mm/min	500 mm/min
Sensing directions	±X, ±Y, -Z	±X, ±Y, -Z	-Z
Maximum stylus overtravel	XY ±12,5°; Z -6 mm	XY ±14°; Z -4,5 mm	6,9 mm
Trigger force with 50mm stylus	XY = 0,3 - 1,4 N (Factory settings = 1 N) Z = 2,5 - 12,5 N (Factory settings = 8,5 N)	XY = 1 N; Z = 6 N	13 N (Trigger force with 50mm sensor)
Battery lifetime in continuous operation (Probing every 2 seconds)	Operation: 500 h Standby: 1 year	Operation: 500 h Standby: 1 year	Operation: 440 h Standby: 1 year
Extensions Ø 25 (0.98")	30mm (1.18"), 50mm (1.97"), 100mm (3.94"), 200mm (7.87")	30mm (1.18"), 50mm (1.97"), 100mm (3.94"), 200mm (7.87")	
Signal transmission	HDR+	HDR+	HDR+
Power supply	1 x 9 V battery block, Alkaline: 550 mAh	1 x 9 V battery block, Alkaline: 550 mAh	1 x 9 V battery block, Alkaline: 550 mAh
Material	Stainless steel, POM	Stainless steel, POM	Stainless steel, POM
Weight without shank	Aprox. 920g	Aprox. 920g	Aprox. 920g
Temperature range	Operation: 10° C - 50° C, Storage: 5° C - 70° C	Operation: 10° C - 50° C, Storage: 5° C - 70° C	Operation: 10° C - 50° C, Storage: 5° C - 70° C
Protection class	IP68: EN60529	IP68: EN60529	IP68: EN60529

* The measuring accuracy depends on the condition (surface finish, surface parallelism) and calibration of the workpiece.

Infrared receiver

The bidirectional infrared receivers can communicate with several touch probe systems on the same machine simultaneously. They have wide transmission and reception angles and can be used for all Hexagon infrared touch probes and tool setters. All necessary components are integrated into the stainless steel casing, so there is no additional interface required in the control cabinet.



m&h IRR91.50

- Dual-probe as well as bidirectional HDR+ Technology
- Available with radial and axial cable outlet
- Processes measurement and temperature data
- Can be universally used and is extremely robust – IP68



m&h IRR91.42

- Processes measurement and temperature data
- Bidirectional HDR+ technology
- No additional module or interface in the control cabinet required
- Designed for mounting directly in the headstock – IP68

	Description	IRR91.50	IRR91.42
Infrared receivers	Signal evaluation	High Data Rate+ (HDR+)	High Data Rate+ (HDR+ and HDR-Bidi (B))
	Weight	1450g = IRR91.50-A (with cable) 1550g = IRR91.50-R ((with cable and protection tube)	100g
	Power Supply	12 - 23 VDC, max. 100 mA	12 - 23 VDC, max. 100 mA
	Temperature range	Operation: 10° - 50°, Storage: 5° - 70°	Operation: 10° - 50°, Storage: 5° - 70°
	Material	Stainless steel	Stainless steel
	Sealing	IP68: EN60529, IEC529/DIN40050	IP68: EN60529, IEC529/DIN40050
	Mounting	2x Cap head screw M5	Air-blow screw M4 thread

State-of-the-art

HDR⁺-infrared transmission

The IRP25.50 uses improved HDR⁺ infrared transmission (High Data Rate⁺). This guarantees that only the system's own signals are processed, ruling out disturbances caused by extraneous light. The HDR⁺ transmission ensures the bidirectional signal transmission between the receiver and probe with a homogeneous directional characteristic over reflecting surfaces. In addition, without loss of process reliability, it also delivers increased transmission power and optimised energy consumption, providing a battery lifetime of up to 1000 hours in continuous operation.

ITE technology and one-touch strategie

ITE (Intelligent Trigger Evaluation) technology makes it possible to pre-position probes at high speed (up to 50 000 mm/min), whereas Hexagon's one touch capability ensures fast and precise probing (up to 2000 mm/min). This means that the infrared probe moves at top speed to the measuring point, so that it can reliably probe at constant measuring speed with only one touch. This considerably accelerates the measuring process and saves valuable production time.

Enhanced activation options

In addition to the proven, reliable mechanical activation options, the IRP25.50 also offers the option of bidirectional activation. This is done using separately coded signals and is therefore not inferior to mechanical methods with regard to reliability.

- Patented pullstud activation
- Patented water-switch activation
- Mechanical HSK activation
- Separately coded ON/OFF infrared activation

Chameleon-technology

- Supports third-party protocols of competitors
- Easy and inexpensive alternative in case of a probe crash
- Simple protocol setting
- No conversion required when changing to Hexagon

Ground-breaking measuring solutions for different applications

High productivity in series production requires flexible and effective measurement solutions. As an experienced supplier in the measuring technology area for machine tools, we ensure the integration the current requirements of our customers into our developments is among our core competences.

Automated temperature measurement

Temperature probe m&h IRP25.50-TP

Fully automatic measurement of the workpiece temperature both before and after machining. Using a patented technology, it enables the control of production processes and the adaptation of machining parameters during production. Temperature-dependent parameters can be reliably determined before the workpiece goes to the next machining step with tolerance specifications. This way, consistently high production quality is ensured.

- The only temperature probes on the market
- Patented technology delivers fast measurement of part temperature for precise production results
- Reliable determination of temperature-dependent parameters enables greater control of production processes



Patented technology

Dual-Probe technology

Simultaneous measurement of two IRP25.50s with just one IRR91.50 receiver.

Activation methods

Pullstuds and water activated switches.

HSK shanks with Thermo-Lock® Technology

Prevents heat expansion of the shank to the probe body.

Tool setter with adjustable positions

Fast changeover to a pre-mounted, magnetic base plate.

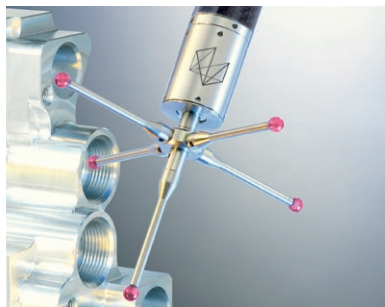
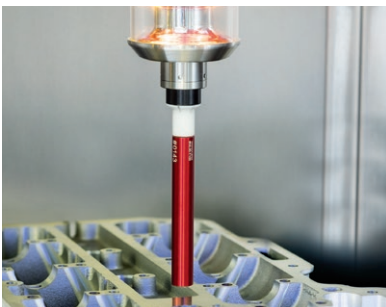
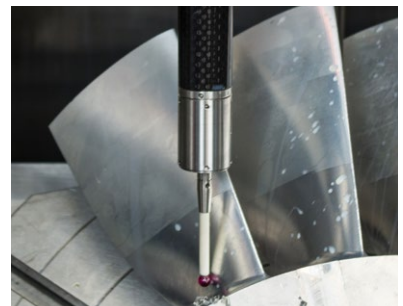
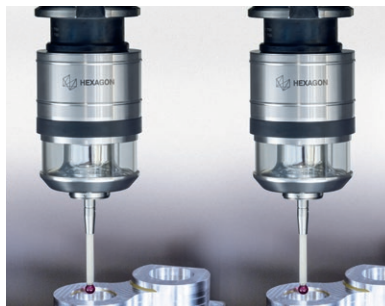
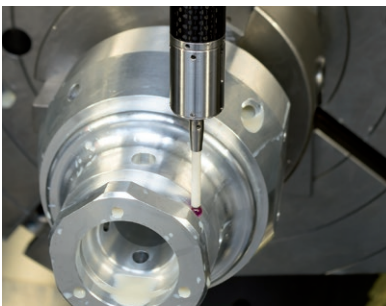



Mass production without compromising quality

Mass production places the highest demands on the production process. Short cycle times in uninterrupted productions require the highest levels of process reliability, coupled with minimum manual intervention.

Infrared probing system m&h IRP40.02 / m&h IRP40.02-LF

Extreme accelerations, high positioning speeds, constant vibrations, hard tool changes, increased temperatures and aggressive coolants are no obstacle for Hexagon touch probes. A compact and robust design means the touch probe can be used for applications within extremely limited spaces.

The IRP40.02-LF has a repeatability of 2 Sigma 0,3µm. Even at higher probing speeds and greater stylus overtravel, the trigger forces of the IRP40.02-LF remain low, protecting highly sensitive workpieces from damage.

- Z-Crash detection guarantees process reliability
- Shorter measurement times without loss of process reliability
- Precise measurements with only one probing
- Up to 800 hours battery lifetime in continuous operation

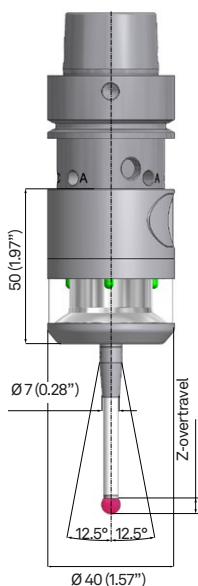

	Description	IRP40.02	IRP40.02-LF
Infrared probing system	Sensing directions	±X; ±Y; -Z	±X; ±Y; -Z
	Maximum stylus overtravel	XY ±12,5°; Z -5mm	XY ±12,5°; Z -5mm
	Static trigger force	XY 0,8 N, Z 5,7 (with 50 mm Stylus)	XY 0,5 ±0,2 N, Z 3,0 N ±10% (with 30 mm stylus)
	Repeatability (deflection from one direction)	Max. 0,5 µm (2 Sigma) with 50 mm stylus and 254 mm/min probing feedrate	Max. 0,3 µm (2 Sigma) with 30 mm stylus and 254 mm/min probing feedrate
	Recommended probing feedrate	Max. 2000mm/min	Max. 1000mm/min
	Power supply	2x battery (3,6 V / ½ AA)	2x battery (3,6 V / ½ AA)
	Max battery life	Approx. 800 h in continuous use, standby 12 months	Approx. 800 h in continuous use, standby 12 months
	Material	Stainless steel	Stainless steel
	Weight without shank	Approx. 390 g	Approx. 390 g
	Temperature range	Operation: 5° C - 55° C Storage: 5° C - 70° C	Operation: 5° C - 55° C Storage: 5° C - 70° C
Sealing	IP68: EN60529	IP68: EN60529	

A wide range of applications

Hexagon offers infrared touch probes with different operating principles for a variety of applications and machine sizes, as well as a manually changeable infrared tool setter system, which can be used alongside any infrared touch probe.



m&h IRP40.42

Specially designed for measuring sensitive materials and thin, fragile workpiece geometries, the measuring unit operates with constantly low trigger forces and can be fitted with a range of styli and spherical measuring tips from $\varnothing 0.2$ mm. Even at higher probing velocity and greater stylus deflection the probing forces on the IRP40.42 remain constantly low to protect delicate, highly sensitive workpieces against damage.

- Constant, minimum probing forces
- Reliable HDR+ infrared transmission
- HSK shanks with Thermo-Lock® Technology

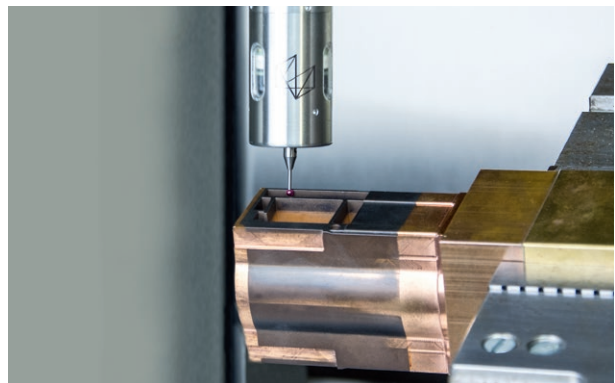

m&h IRP40.50

With a diameter of only 25 millimetres and a length of 42.4 millimetres, this ultrasmall infrared probe can operate in any small machining centre and leaves sufficient space to allow measurement on the Z axis without danger of collision. The IRP40.50 is highly precise and is also suitable for small and delicate workpieces with a low probing force of 1,3 N (X/Y).

- The smallest infrared probe in the world
- Reliable bidirectional HDR infrared transmission
- Energy-efficient and economical

Thermo-Lock® Technology

- Prevents heat transfer from the spindle to the probe
- Eliminates uncontrolled expansion of the shank and probe body
- HSK shanks with Thermo-Lock® technology are available in various sizes

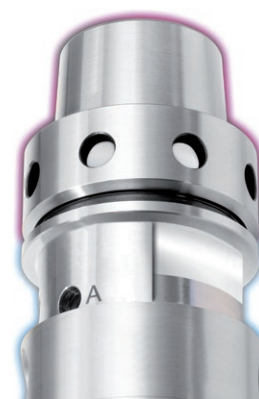



m&h IRT35.70

The Infrared tool setter for milling machines and machining centres enables variable positioning of the tool setter, to fit the task at hand. Through use of a magnetic mount, the tool setter can be placed in a wide range of table positions. Our patent-pending system delivers highly accurate and repeatable re-positioning of the tool setter. No cumbersome cables or other hardware outlines encroach on the machining area. Tool measurement as well as tool breakage controls can be carried out flexibly with only one device.

- Quickly mounted on pre-mounted base plate
- Wireless, removable, no lost machining area
- Can be shared between machines

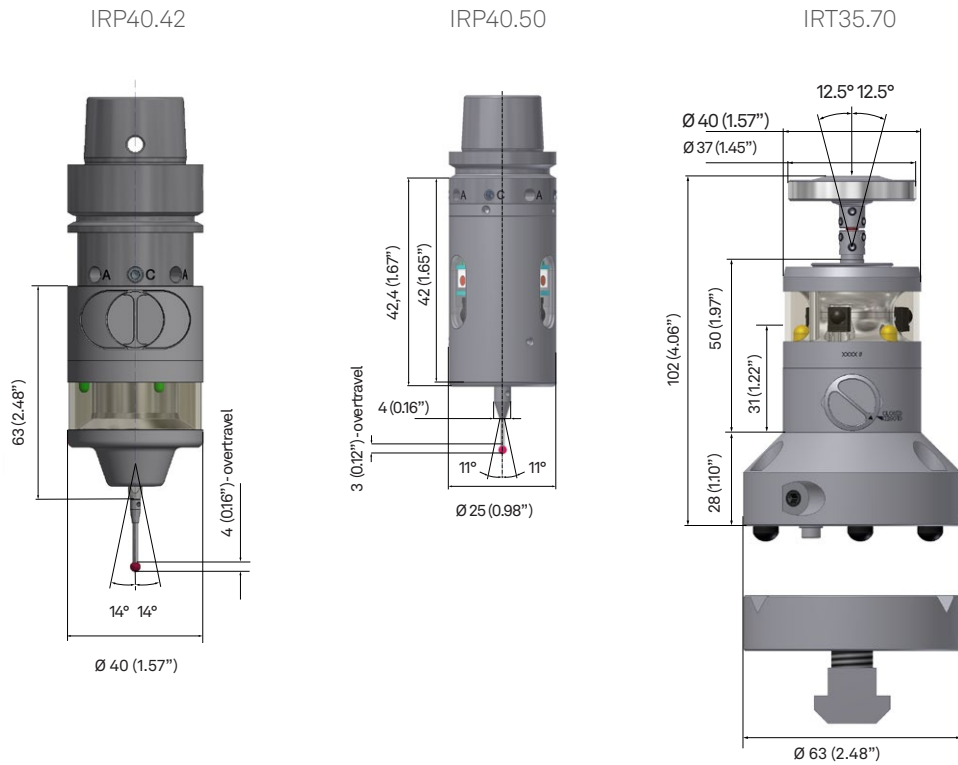

Description	IRP40.42	IRP40.50	IRT35.70
Repeatability at Probing from one direction	2 Sigma $\leq 1 \mu\text{m}$ with 20mm Stylus and 254mm/min	2 Sigma $\leq 1 \mu\text{m}$	2 Sigma $\leq 1 \mu\text{m}$ at 100mm/min
Probing directions	$\pm X, \pm Y, -Z$	$\pm X, \pm Y, -Z$	$\pm X, \pm Y, -Z$
Max. stylus deflection	X/Y $\pm 14^\circ$; Z -4 mm	X/Y = $\pm 11^\circ$; Z = -3 mm	X/Y $\pm 12,5^\circ$; Z -5 mm
Trigger force	X/Y = 0,08 N, Z = 0,8 N	X/Y = 1,3 N, Z = 3 N	X/Y = 2 N, Z = 8 N
Recommended probing	Max. 480 mm/min	Max. 2000 mm/min	-
Power supply	2x batteries (3,6 V / $\frac{1}{2}$ AA)	3 x batteries 3 V, Typ CR2032	1x batterie (3,6 V $\frac{1}{2}$ AA)
Battery lifetime	Approx. 800 h in continuous use (standby 12 months)	Approx. 400h in continuous use	-
Weight without shank	Approx. 250 g	Approx. 78 g	Approx. 750 g (without base plate)
Material	Stainless steel	Stainless steel, polyamide	Stainless steel
Protection class	IP68: EN60529	IP68: EN60529	IP68: EN60529
Temperature range	Operation: $10^\circ - 50^\circ\text{C}$, Storage: $5^\circ - 70^\circ$	Operation: $10^\circ - 50^\circ\text{C}$, Storage: $5^\circ - 70^\circ$	Operation: $10^\circ - 50^\circ\text{C}$, Storage: $5^\circ - 70^\circ$
			Smallest tool for length measurement at probing speed 100 mm/min $\varnothing 0,05 \text{ mm } (0.02")$

Customer stories

Hexagon's high-quality measurement systems are specially designed and made for use in machine tools, offering manufacturers maximum precision and reliability. Here are extracts from testimonials by users of Hexagon probing systems with infrared transmission.

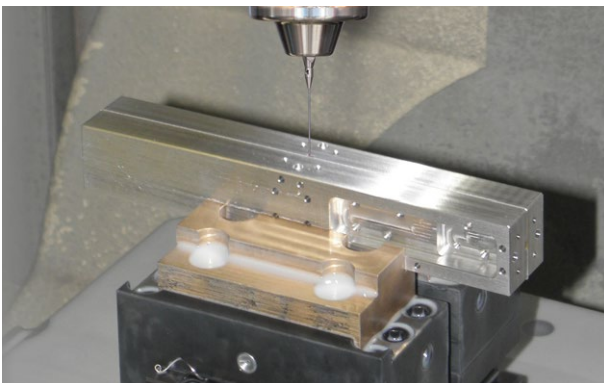

Feinmechanik Leipold, Blechhammer, Germany

By using styli with tooling balls as small as 0.2 mm in diameter the company can measure even the smallest of contours with the lowest possible measuring force. And because Feinmechanik Leipold uses the Thermo-Lock® version of the IRP40.40-LF touch probe, it means "we no longer have any deviation along the Z axis", according to Fredi Leipold of Feinmechanik Leipold. Patented by Hexagon, Thermo-Lock® technology prevents heat expansion of the shank to the probe body or measuring unit.

“The company benefits from “more accuracy, less reworking and gains in production time thanks to Hexagon touch probes”

enthuses Fredi Leipold,
owner of Feinmechanik Leipold

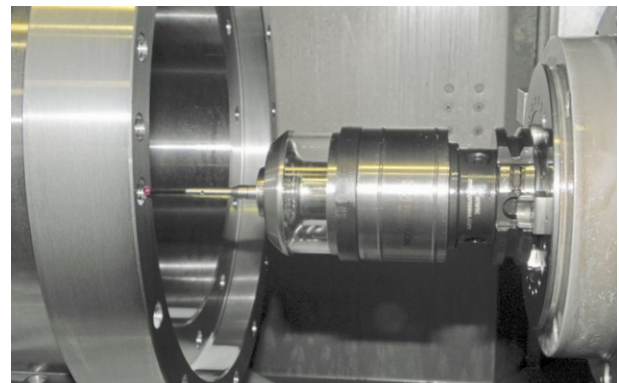

Werkzeug- und Maschinenfabrik RAY AG, Nänikon, Switzerland

Werkzeug- und Maschinenfabrik chose the IRP25.50 for its excellent signal emission, achieved because its transmitter diodes are arranged so that their signals are reflected on polished surfaces and emitted consistently. In addition, toughened glass protects these diodes from the effects of all coolant and chips and because everything is sealed to the IP68 standard, it can withstand pressure of up to one metre of water depth.

“After our negative experiences with other products, this was a decisive factor for us”

explains Andi Baumann,
produktion manager at Ray AG



Hexagon is a global leader in sensor, software and autonomous solutions. We are putting data to work to boost efficiency, productivity, and quality across industrial, manufacturing, infrastructure, safety, and mobility applications.

Our technologies are shaping urban and production ecosystems to become increasingly connected and autonomous – ensuring a scalable, sustainable future.

Hexagon's Manufacturing Intelligence division provides solutions that utilise data from design and engineering, production and metrology to make manufacturing smarter. For more information, visit hexagonmi.com.

Learn more about Hexagon (Nasdaq Stockholm: HEXA B) at hexagon.com and follow us [@HexagonAB](https://twitter.com/HexagonAB).